

MODELING OF A MULTILAYERED PROPELLANT EXTRUSION IN CONCENTRIC CYLINDERS

Boston COMSOL Conference, October 8th, 2015
By Simon Durand, Charles Dubois & Pierre G. Lafleur,
Viral Panchal & Duncan Park

Background

- ▶ Existing technologies optimizing internal ballistic :
 - ▶ Gas generation rate progressivity optimization
 - ▶ Energy density increase
- ▶ Progressivity:
 - ▶ Perforated propellant: Creates more surface area available for combustion as the propellant is consumed.
 - ▶ Coated propellant: Adding an inert plasticizer on the surface of the propellant reducing its burning rate at the beginning of the cycle.

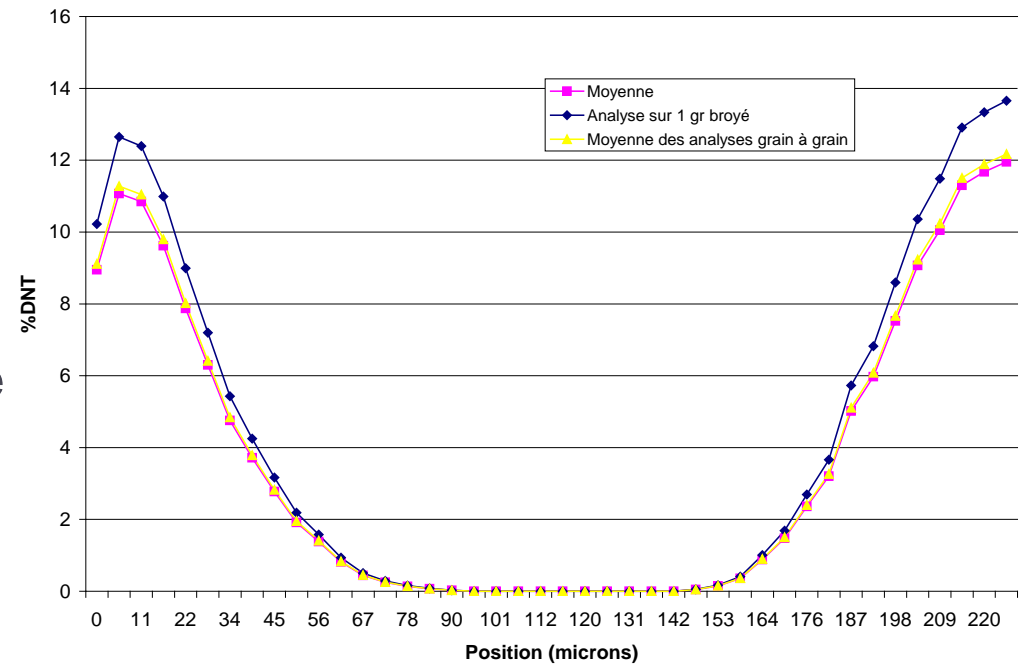
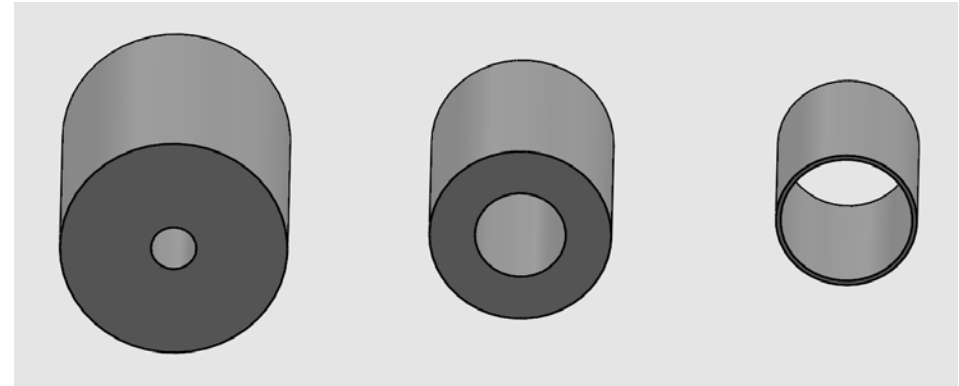

Background: Coextrusion



POLYTECHNIQUE
MONTRÉAL

LE GÉNIE
EN PREMIÈRE CLASSE

- ▶ A new patented technology is being developed at General Dynamics OTS Canada to outperform existing propellant: The multilayered propellants² :

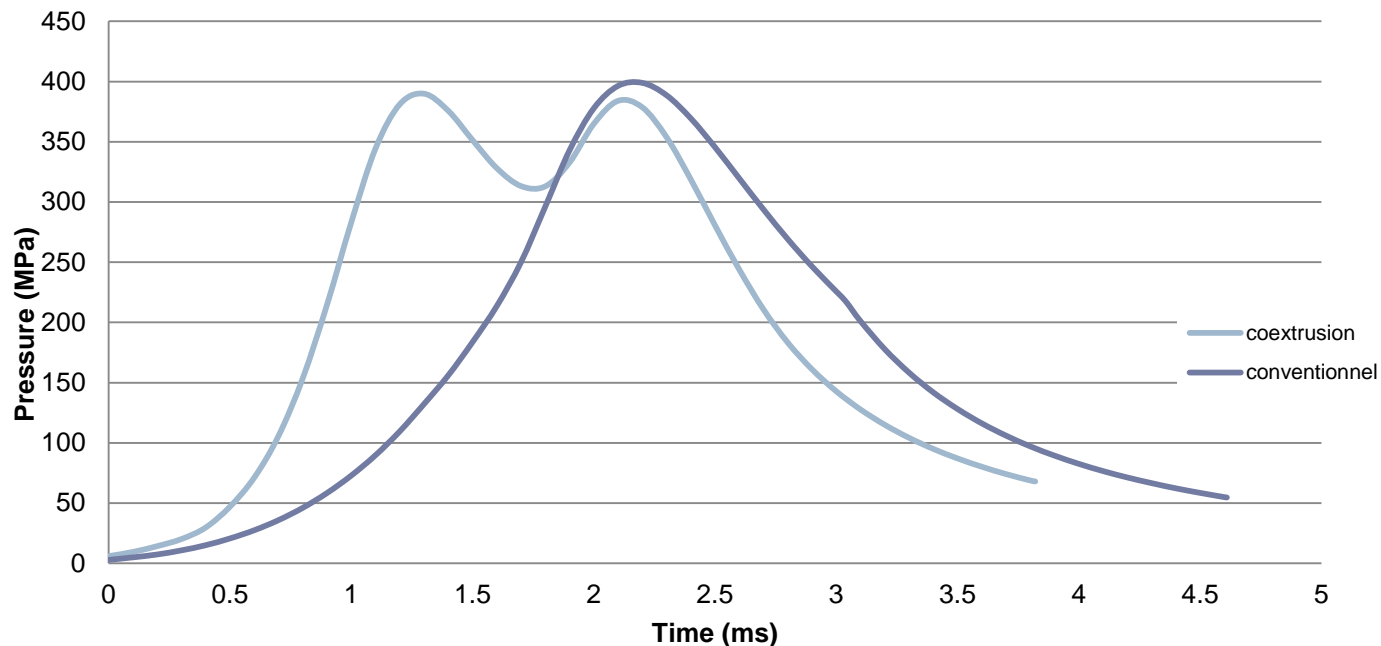

Internal ballistic simulation showing the advantages of optimized multilayered propellant as compared to conventional.

Objective



POLYTECHNIQUE
MONTREAL

LE GÉNIE
EN PREMIÈRE CLASSE

- ▶ To replace the inert material coating by the extrusion of multilayered propellants in concentric cylinders:

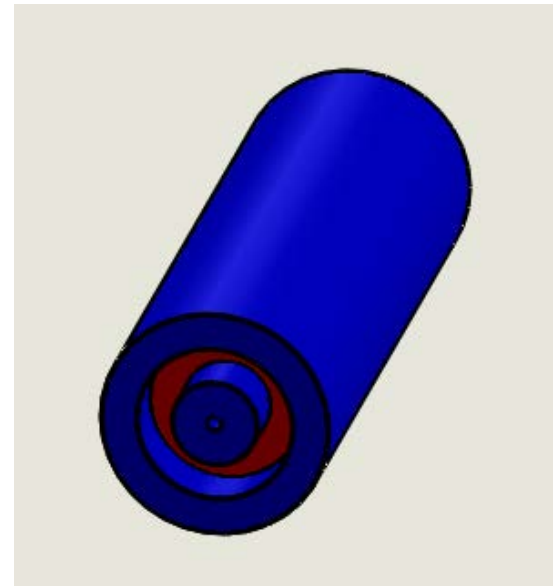
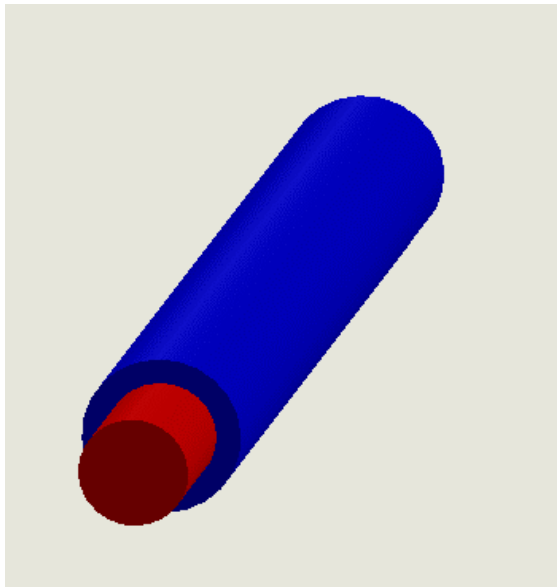

- ▶ Tuning such propellant to a system requires several die geometries. To avoid a trial and error process, a numerical simulation was used.

Challenges

- ▶ Different path lengths between the inner and outer sections of the die, both coming from the same pressure driven flow (in blue)
- ▶ Highly shear thinning materials
- ▶ Completely different viscosity between mid section (red) and adjacent section (blue)

Power law, blue layers:

$$\eta = 226000 * \dot{\gamma}^{(0.205-1)}$$

Power law, red layer:

$$\eta = 100 * \dot{\gamma}^{(0.55-1)}$$

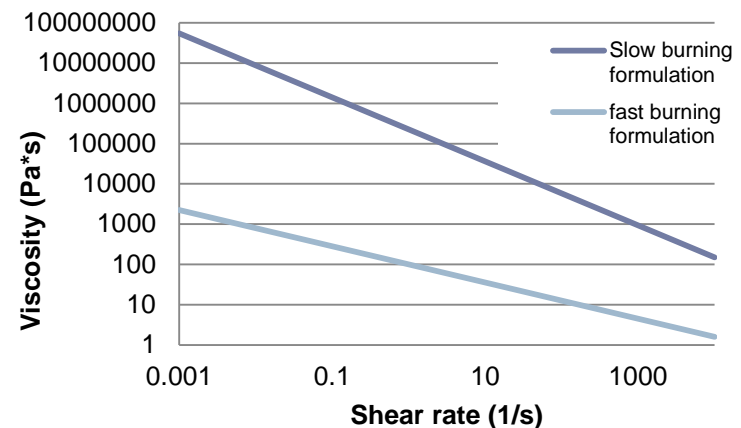
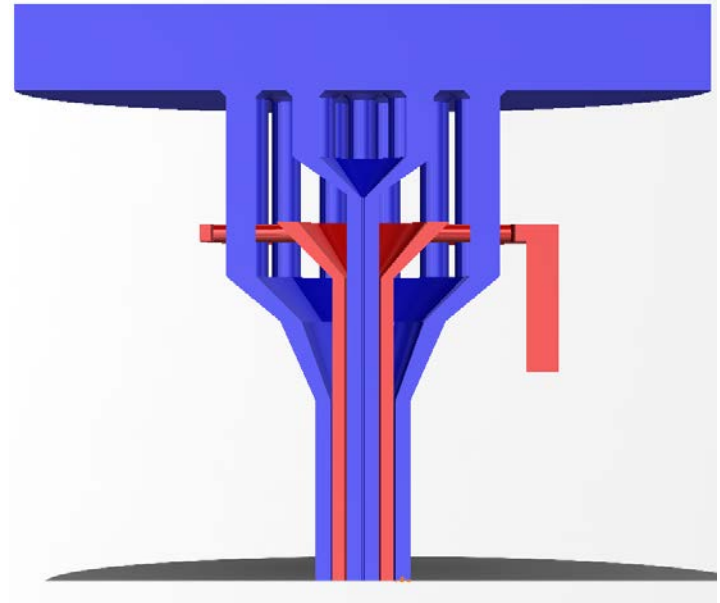

Model on COMSOL

► Variables:

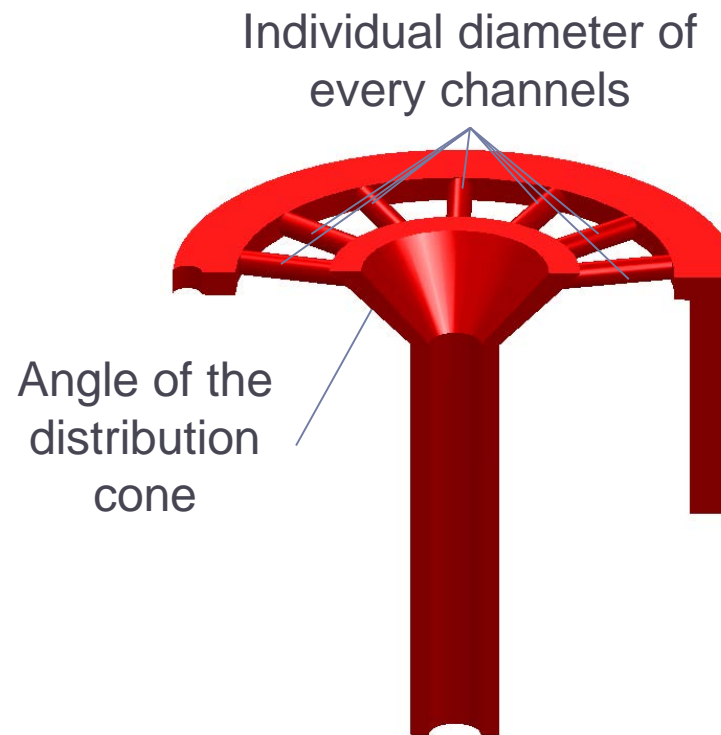
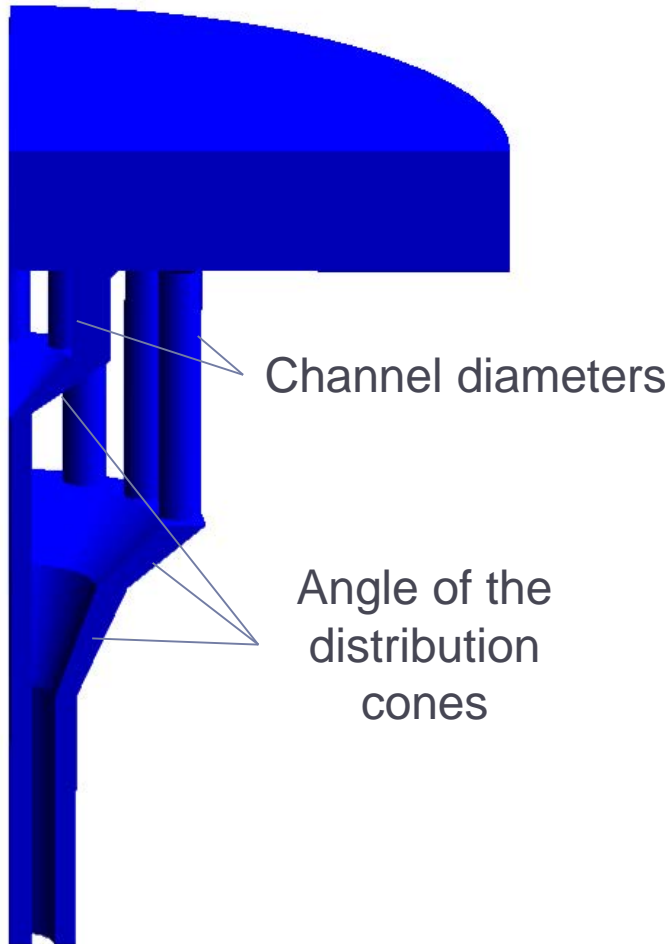

Isothermal Flow Study: Fast Burning Formulation



POLYTECHNIQUE
MONTRÉAL

LE GÉNIE
EN PREMIÈRE CLASSE

▶ Flow balance of the fast formulation:

- ▶ parameter: channel diameters
- ▶ Viscosity model: $100 * \dot{\gamma}^{n-1}$
- ▶ Isothermal
- ▶ n from 0.6 to 0.4
- ▶ Meshing: approximately 185,000 tetrahedral elements
- ▶ No wall slip
- ▶ Inlet pressure: 138 kPa

Channel diameters

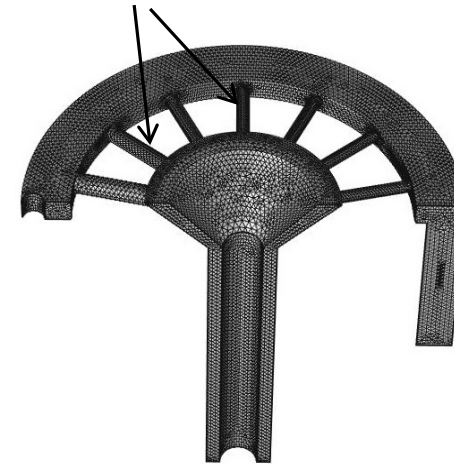

Tetrahedral element distribution in the fast formulation model.

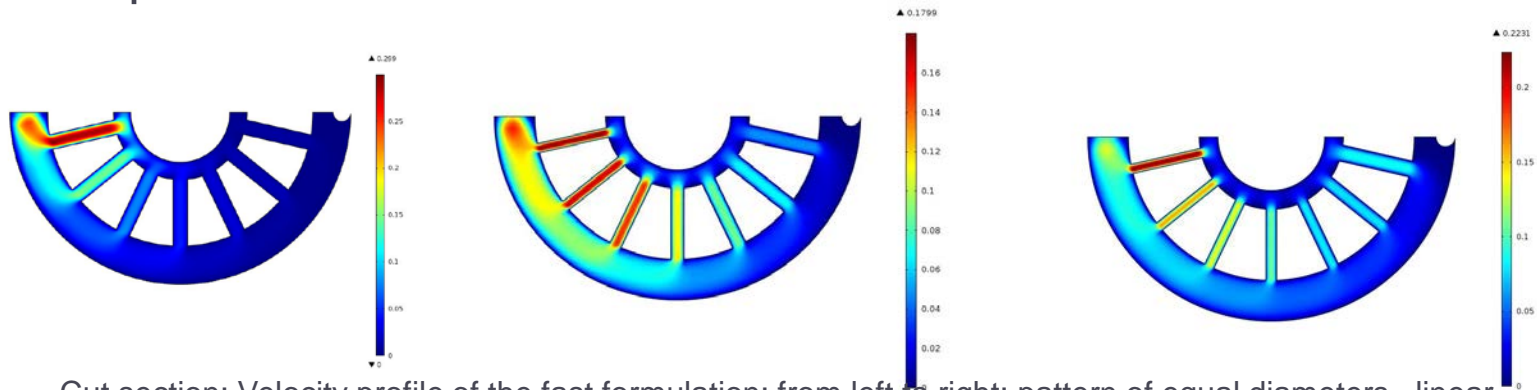

Cut section: Velocity profile of the fast formulation: from left to right: pattern of equal diameters, linear increase, exponential increase. Images taken at $n=0.4$

Isothermal Flow Study: Slow Burning Formulation



POLYTECHNIQUE
MONTREAL

LE GÉNIE
EN PREMIÈRE CLASSE

- ▶ Two designs are presented:
 - ▶ The first one possess 8 external channels and the flow of this section is restrained by narrow distribution cones. Internal flow is maximized.
 - ▶ The second design, optimized, possess 14 external channels and large distribution cones to maximize external flow. The internal section is restrained by a narrower cone.
 - ▶ Each model contains approximately 260,000 tetrahedral elements.

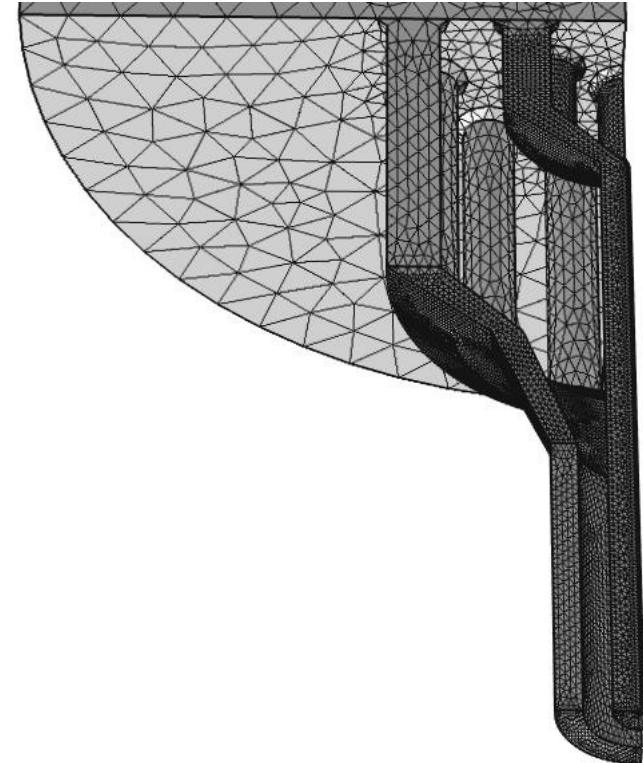

Typical representation of the element distribution during the isothermal studies. (Second design).

Isothermal Flow Study: Slow Burning Formulation



POLYTECHNIQUE
MONTRÉAL

LE GÉNIE
EN PREMIÈRE CLASSE

▶ First design :

- ▶ 8 external channels , the inner section is favored for low values of n
- ▶ Viscosity model used : $\eta = k * \dot{\gamma}^{n-1}$
- ▶ $k = 198,000 \text{ Pa}\cdot\text{s}^n$
- ▶ n value was evaluated from 1 to 0.2
- ▶ isothermal
- ▶ No wall slip
- ▶ Inlet flow rate : $4.54 \text{ cm}^3/\text{s}$

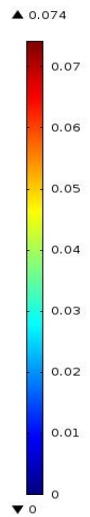
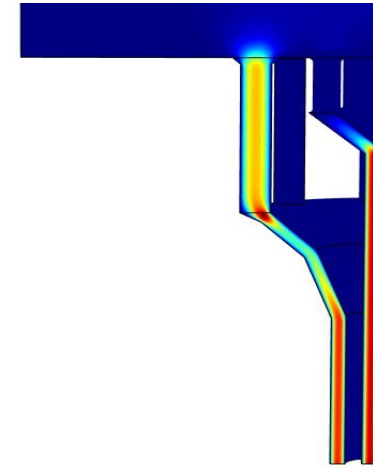
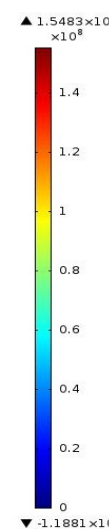
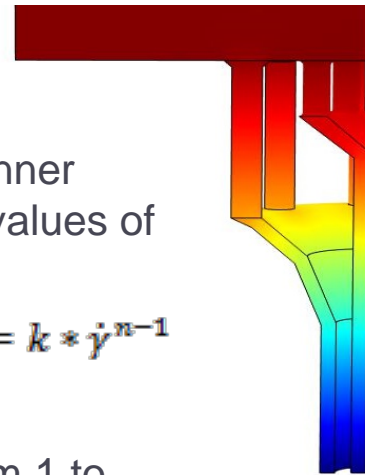

Pressure (Pa) and flow (m), inlet flow rate $4,54 \text{ cm}^3/\text{s}$, design no.1 $n=0,721$

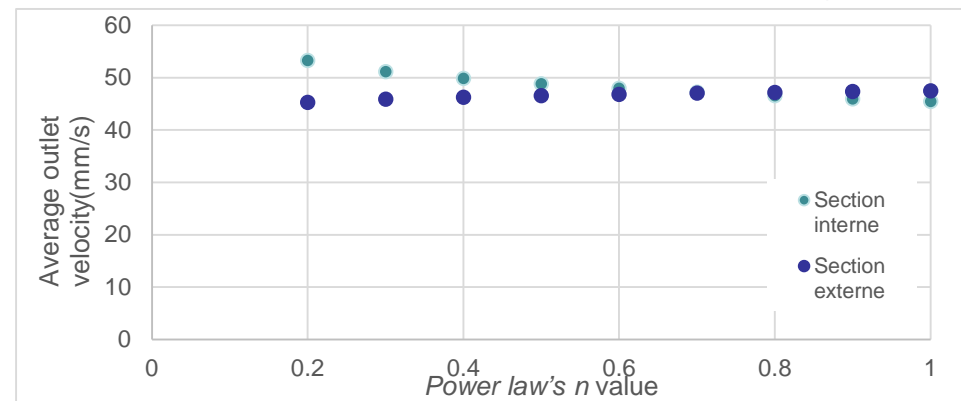

Design no. 1 (8 external channels) average outlet velocity comparison between internal and external outlets as a function of n .

Isothermal Flow Study: Slow Burning Formulation



POLYTECHNIQUE
MONTREAL

LE GÉNIE
EN PREMIÈRE CLASSE

▶ Optimized design :

- ▶ 14 external channels, external section is favored on a wide range of n value
- ▶ Viscosity model: Power law: $\eta = k * \dot{\gamma}^{n-1}$
- ▶ $k = 198,000 \text{ Pa} \cdot \text{s}^n$
- ▶ n value is evaluated from 1 to 0.1
- ▶ isothermal
- ▶ No wall slip
- ▶ Inlet flow rate: $4.54 \text{ cm}^3/\text{s}$

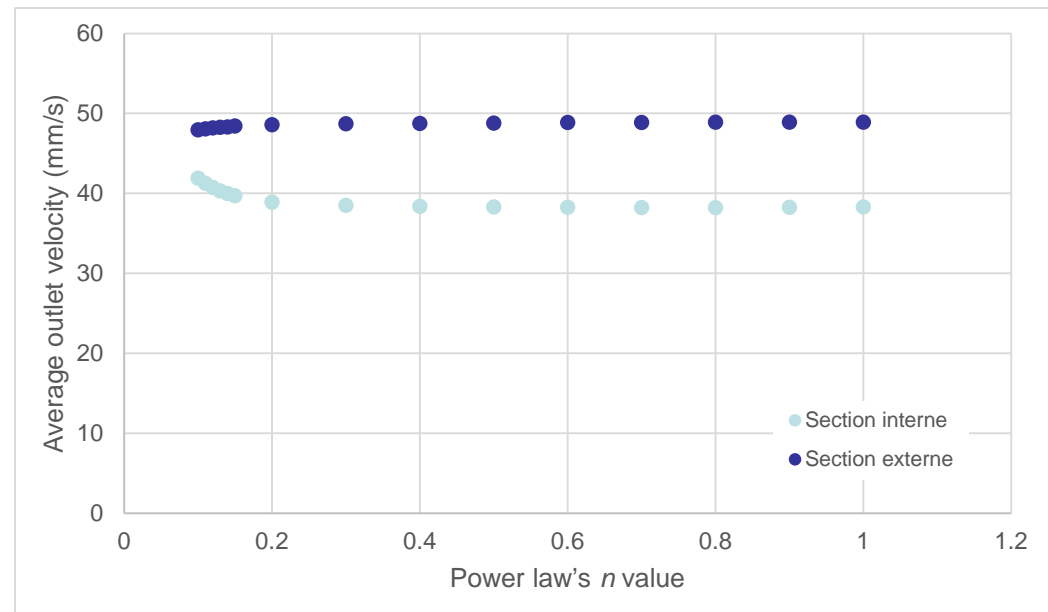

Design no. 2 (14 external channels) average outlet velocity comparison between internal and external outlets as a function of n .

Isothermal Flow Study: Slow Burning Formulation



POLYTECHNIQUE
MONTREAL

LE GÉNIE
EN PREMIÈRE CLASSE

- ▶ Velocity profile example for different n values.

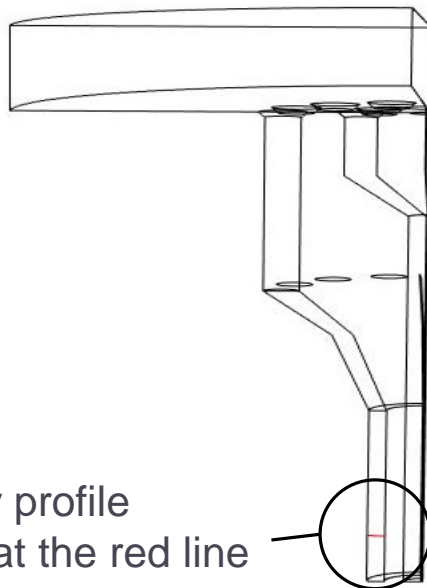

Velocity profile
shown at the red line

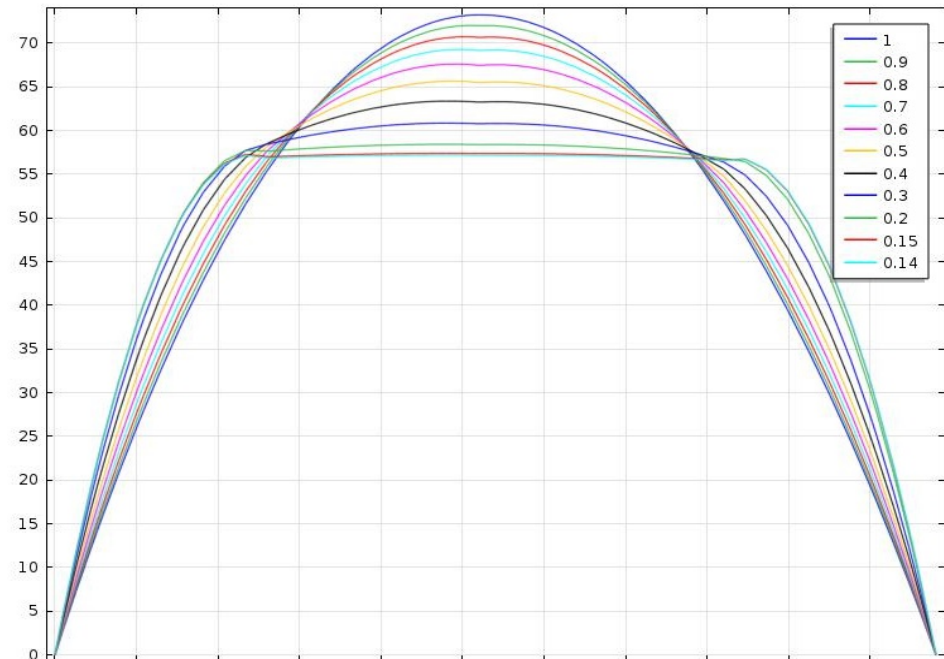

Velocity distribution in mm/s of the external section shown at the red line for different n values.

Isothermal Flow Study: Slow Burning Formulation



POLYTECHNIQUE
MONTREAL

LE GÉNIE
EN PREMIÈRE CLASSE

Shear rate distribution (1/s)

n(1)=1 Volume: Shear rate (1/s)

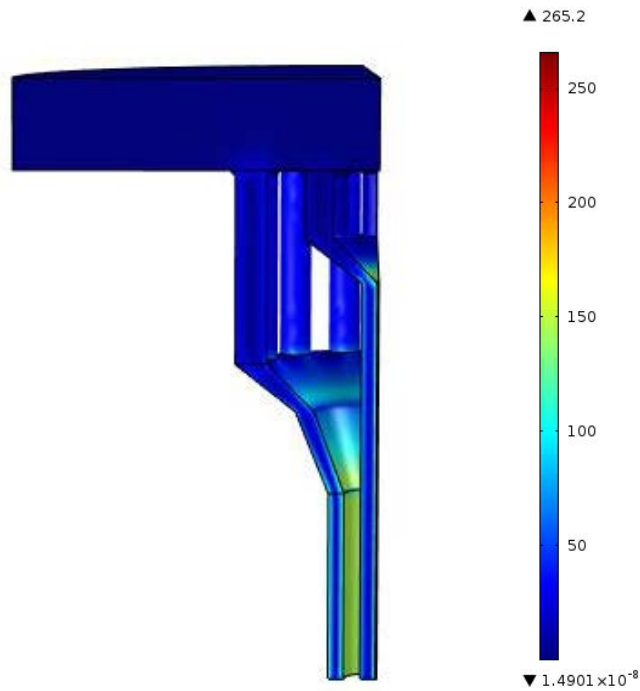

n = 1

Shear rate distribution (1/s)

n(11)=0.14 Volume: Shear rate (1/s)

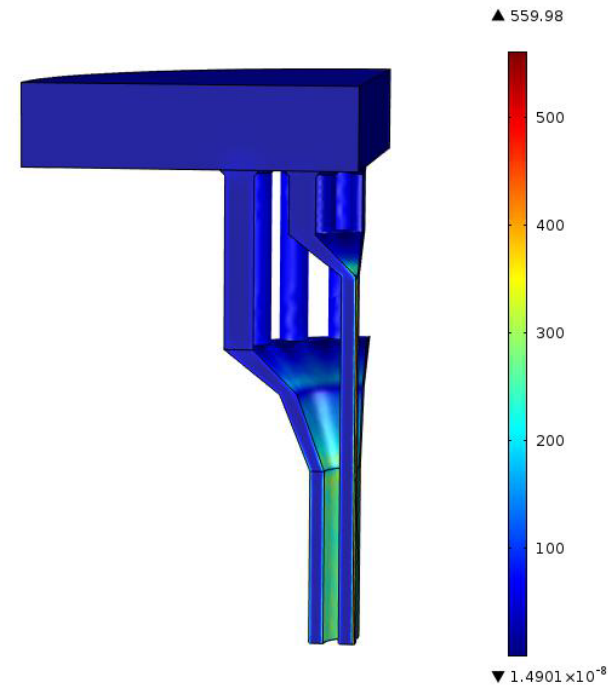

n=0.14

Non-Isothermal Flow Study: Slow Burning Formulation w/ viscous heating



POLYTECHNIQUE
MONTRÉAL

LE GÉNIE
EN PREMIÈRE CLASSE

- ▶ Flow simulations including heat transfer and viscous heating :
 - ▶ Slow burning formulation only, the fast burning formulation section stays empty (air)
 - ▶ Tests demonstrate that the inner section accelerates compared to the isothermal simulations in these conditions
 - ▶ The mesh contains around 500,000 tetrahedral elements
 - ▶ $n = 0.205$

$$\eta = \exp\left(\frac{2864,8}{T} + 2,606\right) * \dot{\gamma}^{(n-1)}$$

Inlet Pressure:	24,82 MPa
Inlet Temperature:	293.15K
Density:	1510kg/m ³
Thermal capacity at constant pressure:	2000J/(kg*K)
Specific heat ratio:	1
Thermal Conductivity (M. S. Miller):	0.294W/(m*K)

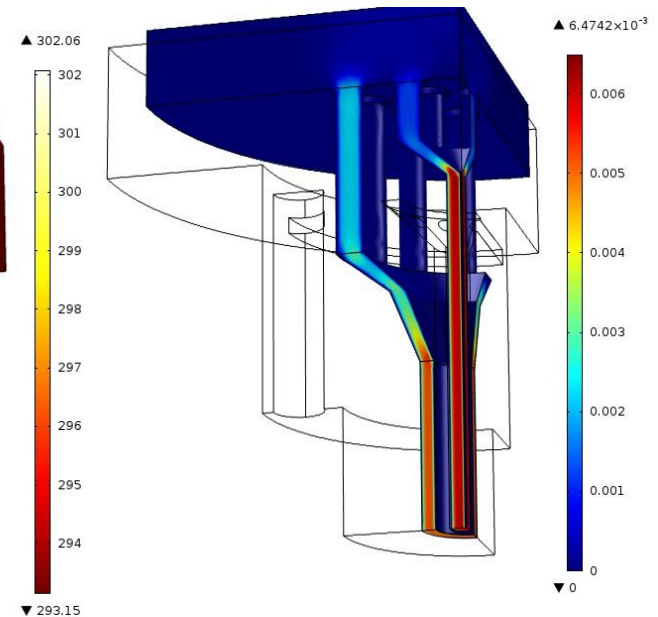
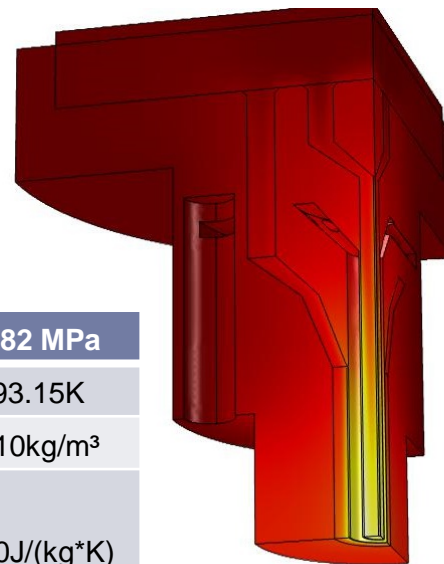

In the left figure is heat distribution in K; right figure shows velocity distribution in m/s of the slow formulation.

Model Verification, Slow Burning Formulation Only



POLYTECHNIQUE
MONTREAL

LE GÉNIE
EN PREMIÈRE CLASSE

- ▶ Model prediction where the inner section become faster than the outer section is confirmed on the ram press as shown on the pictures below:

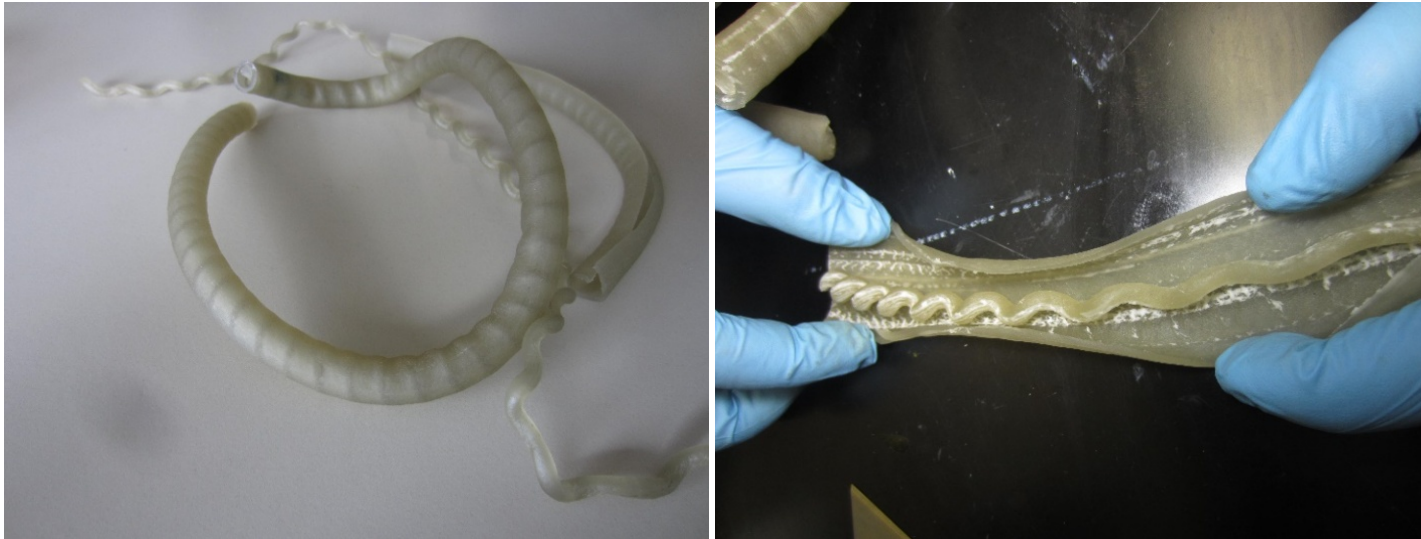

Extrusion results for the 14 channel die (design no. 2) without fast burning formulation in the center (double base propellant).

Verification, Cooled Central Section



POLYTECHNIQUE
MONTREAL

LE GÉNIE
EN PREMIÈRE CLASSE

- ▶ Another verification has been conducted but this time with the die cooled with a stream of water at 14°C circulating in the fast burning formulation section:



Balanced flow from the 14 channel die (design no.2) obtained by cooling the die with water from the fast burning formulation section.

Complete Simulation, Both Formulations with Heat Transfer and Viscous Heating



POLYTECHNIQUE
MONTREAL

LE GÉNIE
EN PREMIÈRE CLASSE

- ▶ Finite element simulations have been conducted combining heat transfer and CFD module. Viscous heating and heat transfer were considered.
- ▶ Mesh : Around 500,000 tetrahedral elements.

	Slow burning formulation	Fast burning formulation
Inlet pressure:	24.82 MPa	0.086MPa
Inlet temperature:	293.15K	293.15K
Density:	1510kg/m ³	1640kg/m ³
Thermal capacity at constant pressure:	2000J/(kg*K)	2000J/(kg*K)
Specific heat ratio:	1	1
Dynamic viscosity (Pa*s):	$\eta = e^{\left(\frac{2848,8}{T} + 2,606\right)} * \dot{\gamma}^{(0,205-1)}$	150
Thermal conductivity:	0.294W/(m*K)	0.3W/(m*K)

Complete Simulation, Both Formulations with Heat Transfer and Viscous Heating



POLYTECHNIQUE
MONTREAL

LE GÉNIE
EN PREMIÈRE CLASSE

Results :

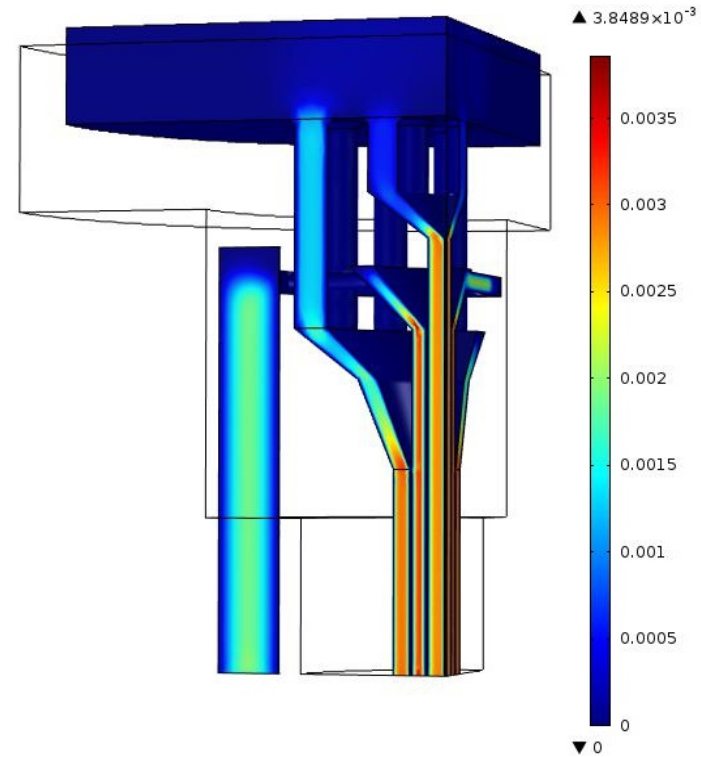
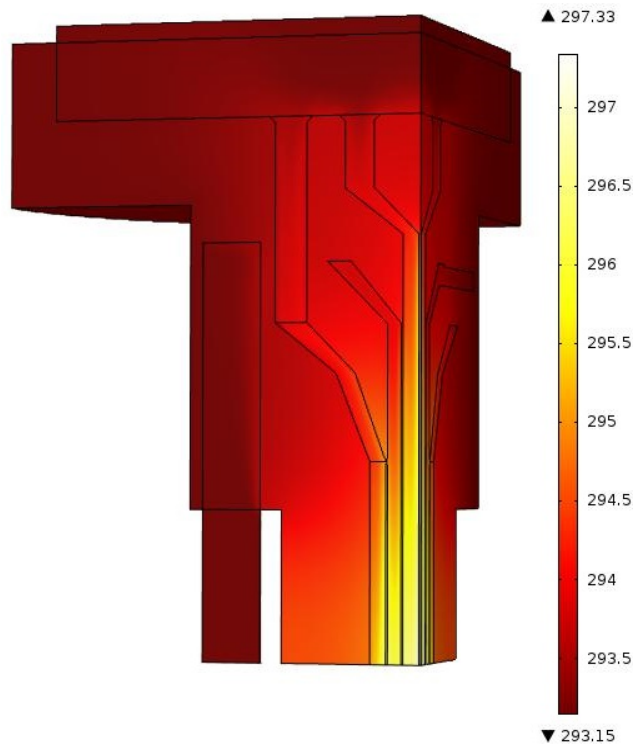

Left: heat distribution in K, right: Velocity distribution in m/s of the slow formulation.

Model Verification, Balanced Flow



POLYTECHNIQUE
MONTREAL

LE GÉNIE
EN PREMIÈRE CLASSE

- ▶ Preliminary results show a correlation with finite elements prediction realized on COMSOL Multiphysics™

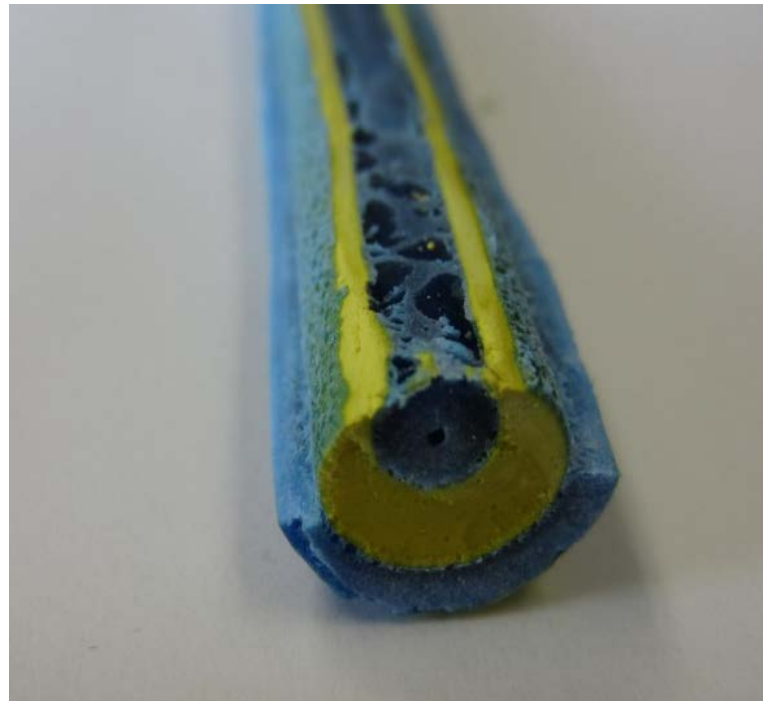

Cut section of the first trial results of multilayered extrusion with one perforation (inert material).

Discussion



POLYTECHNIQUE
MONTREAL

LE GÉNIE
EN PREMIÈRE CLASSE

- ▶ Experimental verifications have established a high confidence level on the robustness of the simulation models using COMSOL Multiphysics™.
- ▶ Isothermal simulations have shown the importance of considering the flow factor n or the shear thinning characteristic of the propellant dough when designing an extrusion die of a complex geometry
- ▶ However, these isothermal simulations alone are not sufficiently accurate to predict a precise extrusion behavior. Due to the high level of viscous heating and the poor thermal conductivity of the material, heat transfer must be also considered.

Conclusion



POLYTECHNIQUE
MONTREAL

LE GÉNIE
EN PREMIÈRE CLASSE

- ▶ The balance of the flow velocity between the inner and outer section was the main challenge of the effort. To address this challenge, viscous heating and shear thinning behavior in the die design have been considered.
- ▶ The simulations are concluding with the interaction between the power law index n and the viscous heating in the die design.
- ▶ The results obtained by finite elements simulations have been validated experimentally.

Modified Westheimer Discovery



POLYTECHNIQUE
MONTREAL

LE GÉNIE
EN PREMIÈRE CLASSE

*“A couple of months in the laboratory can often save a couple hours [on Comsol™].”
- Frank Westheimer (edited)*

Acknowledgement



POLYTECHNIQUE
MONTREAL

LE GÉNIE
EN PREMIÈRE CLASSE

- ▶ École Polytechnique de Montréal: Prof. Marie-Claude Heuzey
- ▶ General Dynamics OTS Valleyfield: Pierre-Yves Paradis, Daniel Lepage, Frederick Paquet and Michel couture
- ▶ US Army ARDEC: Elbert Caravaca, and Joseph Laquidara.
- ▶ RDDC Valcartier: Dr. Catalin Florin, Petre and Marc Brassard

References



POLYTECHNIQUE
MONTREAL

LE GÉNIE
EN PREMIÈRE CLASSE

1. S. Durand, 'Mise en Oeuvre des Propulsifs Multicouches en Filières Concentriques', *École Polytechnique de Montréal*, December 2013
2. S. Durand, P.-Y. Paradis, and D. Lepage, "Method of Manufacturing Multi-Layered Propellant Grains," Patent, WO2015021545 February 2015.
3. M. S. Miller, 'Thermophysical Properties of Six Solid Gun Propellant', *Army Research Laboratory Report, ARL-TR-1322*, March 1997

Model Configuration



POLYTECHNIQUE
MONTREAL

LE GÉNIE
EN PREMIÈRE CLASSE

File Edit View Options Help

Model Builder

- stuff inside 4 under.mph (root)
 - Global Definitions
 - Model 1 (mod1)
 - Definitions
 - Boundary System 1 (sys1)
 - View 1
 - Geometry 1
 - Materials
 - Material 1 (mat1)
 - Material 2 (mat2)
 - 316 (UNS S31600) [solid,723K] (mat3)
 - Creeping Flow (spf)
 - Fluid Properties 1
 - Wall 1
 - Initial Values 1
 - Symmetry 1
 - Symmetry 2
 - Inlet 1
 - Outlet 1
 - Inlet 2
 - Heat Transfer in Fluids (ht)
 - Heat Transfer in Fluids 1
 - Thermal Insulation 1
 - Initial Values 1
 - Outflow 1
 - Temperature 1
 - Heat Transfer in Solids 1
 - Inflow Heat Flux 1
 - Inflow Heat Flux 2
 - Convective Heat Flux 1
 - Symmetry 1
 - Symmetry 2
 - Mesh 1
 - Study 1
 - Study 2
 - Results

– Output properties

Property	Variable	Expression	Unit	Size
Density	rho	1510	kg/m ³	1x1
Dynamic viscosity	mu	$\exp((2848.8/T)+2.606)*spf.sr^{(0.205-1)}$	Pa·s	1x1
Heat capacity at constant pressure	Cp	2000	J/(kg·K)	1x1
Ratio of specific heats	gamma	1.3	1	1x1
Thermal conductivity	k ; kii = k, kij = 0	0.294	W/(m·K)	3x3

Model Configuration



POLYTECHNIQUE
MONTREAL

LE GÉNIE
EN PREMIÈRE CLASSE

The screenshot displays the ANSYS Workbench Model Builder interface. The left pane shows a tree view of the model structure, with 'Parametric 1' selected under 'Solver Configurations'. The right pane shows the 'Parametric' configuration settings.

General

Defined by study step: User defined

Sweep type: Specified combinations

Parameter names	Parameter value list
n	0.5 0.4 0.3 0.25 0.205 0.186 0.163 0.140

Predictor: Automatic

Load Case

Define load cases

Load case